



Professional Engineering Exam Chemical Engineering Study Guide

Saudi Council of Engineers (SCE)
Education and Training Evaluation Commission (ETEC)
National Center for Assessment (NCA)

www.etec.gov.sa



May 2019

COPYRIGHT NOTICE

Copyrights © 2019 National Center for Assessment (NCA) Unless stated otherwise, copyright in this report (including content and design) is owned by the National Center for Assessment (NCA)- Riyadh – Saudi Arabia. EXCEPT with the expressed written permission from NCA, you may not reproduce, use (in particular for academic or commercial purposes), store in a retrieval system, adapt, modify, communicate to the public or photocopy any part of this report.

Table of Contents

	Page
Copyright Notice	2
1. Aim	4
2. Exam Structure	4
3. Table of Specifications	7
4. Standards for Chemical Engineering	8
5. Samples of Questions	15
6. Solution of Samples of Questions	23

1. Aim:

The objective of this Instruction Manual is to provide guidelines for the proposed NCA Professional Engineers Exam. These guidelines cover the eligibility conditions, the grading and passing conditions, the structure of the exam, and the distribution of exam questions among various areas. In essence, this Instruction Manual represents a “bridge” between the developed exam standards and the actual phrased questions. It is designed to help item writers prepare questions for the Chemical Engineering Discipline paper as well as study guide for the examinees.

2. Exam Structure:

2.1 Exam Type

The exam is initially paper-based with questions being a combination of multiple-choice questions (MCQ) and essays.

2.2 Exam Organization

The exam will be conducted in two sessions during one day. The duration of the first session is 2.5 hours while the second session is 4 hours long. There is one-hour break between the two sessions.

2.2.1. Session #1

The first session is the common part to be taken by all the examinees from all disciplines. This part includes seven topics: (Ethics – Professionalism - Laws for Professional Practice, Professional Laws and Regulation - Environment and Natural Resources - Engineering Management - Engineering Economics - Health, Safety & Security (HSS)).

The total duration of this session is 2.5 hours and the total number of questions is 30 MCQ and 2 essays.

2.2.2. Session #2

The second session is the Discipline Part. The following engineering disciplines are considered:

Code	Discipline
STE	Structural Engineering
GTE	Geotechnical Engineering
TRE	Transportation Engineering
WREE	Water Resources and Environmental Engineering
PE	Power Engineering
HVAC	Heating, Ventilation, and Air Conditioning (HVAC) and Refrigeration Engineering
TFSE	Thermal and Fluids Systems Engineering
CHE	Chemical Engineering
FPE	Fire Protection Engineering
ARCH	Architecture

The total duration of this session is 4 hours and the total number of questions is 30 MCQs and 4 essays. The examinee must answer all the MCQs and two essays out of four.

2.3 Eligibility for the Exam

As per Saudi Council of Engineers Requirements.

2.4 Grades

Each part (common part and discipline part) carries a total grade of 100. The MCQs carry a grade of 60% while the essays carry a grade of 40%. Each MCQ has 4 choices for the answer. There is no negative marking for wrong answers.

2.5 Passing Rules

- The eligible candidate must take in his/her first sitting the two exam parts (common part and discipline part).
- In order to pass the exam, the candidate must obtain a grade of 60% or above in each part of the exam.
- If the candidate fails both parts of the exam (by receiving in each part a grade less than 60%), he/she can take the two parts of the exam but only when one full year has passed.
- If the candidate fails only one part of the exam (common part or discipline part), he/she must repeat only the part he/she failed, but he/she must pass this part within one year.
- If a year passed and the candidate did not succeed in passing the part he/she failed, then he/she has to take both parts of the exam.

2.6 Exam Rules

- No printed or electronic material is allowed during the exam. All necessary reference materials will be provided by NCA.
- Calculators approved by NCA are allowed.
- Comprehensive exam rules will be provided by the examination authority, NCA, in a separate manual.

3. Table of Specifications for NCA Professional Engineers Exam: Chemical Engineering:

Major Area	Multiple Choice Questions (MCQs)		Essay Questions	Engineering Standard
	% of Test	# Q		
1- Health, Safety, and Environment in CHE Plants	26.7%	8	1	CHE-T1
2- Design	36.7%	11	1	CHE-T2
2-A: Unit Design	23.3%	7		CHE-T2-A
2-B: Process and Plant Design	13.3%	4		CHE-T2-B
3- Operation	23.3%	7	1	CHE-T3
4- Management and Economics of CHE Plants	13.3%	4	1	CHE-T4
Total	100%	30	Choose 2 out of 4	

4. Standards for Chemical Engineering Exam:

The Engineering Standards for the Chemical Engineering (CHE) Discipline are structured around four major areas practiced in Chemical Engineering field worldwide.

1. Health, safety, and environment in CHE plants,
2. Design,
3. Operation,
4. Management and Economics of CHE plants

Each area is composed of a number of Indicators that cover the main areas of practice in Chemical Engineering.

Professional Engineers in Chemical Engineering are expected to possess and demonstrate command of the following major areas in CHE practice.

CHE-T1: Health, Safety, and Environment in CHE Plants (8 MCQs)

- CHE-T1-1 Assess, analyze, prevent, and mitigate potential hazards in chemical plants.
- CHE-T1-2 Understand and apply the inherently safer design (ISP) philosophy when designing a plant.
- CHE-T1-3 Ensure process safety by including protection systems in the design: (relief valves, rupture disks, vents, discharge location).
- CHE-T1-4 Ensure work place safety by including in the design: emergency routes/exits, ventilation for hazardous gases, sufficient lighting for workplaces, fall protection, protection against hot surfaces, emergency showers.
- CHE-T1-5 Implement a fire fighting concept based on the layout and inventory of the plant (detection/surveillance systems, fire fighter attack routes, fire sections, extinguishing systems, smoke ventilation).
- CHE-T1-6 Analyze, manage, and reduce or eliminate risks in the plant.
- CHE-T1-7 Perform and apply HAZOP analysis and subsequent assessment of required barrier quality level (e.g. layer of protection analysis, risk graph).
- CHE-T1-8 Ensure correct layout and distancing of plant equipment and buildings (control room, offices, important utility installation) according to potential scenarios (e.g. explosions).
- CHE-T1-9 Ensure correct zoning of the plant in terms of risk regarding explosive atmosphere and the suitability of installed equipment accordingly.
- CHE-T1-10 Enforce use of personal protection equipment.
- CHE-T1-11 Reduce/Recycle/Reuse, manage, and dispose properly the plant's liquid and solid wastes.



- CHE-T1-12 Quantify, mitigate, and treat gaseous emissions.
- CHE-T1-13 Understand and strictly follow Safety Data Sheet (SDS) for raw materials, products and any chemical used in the plant.
- CHE-T1-14 Apply proper procedures for all the activities inside the plant including storing, transporting, and handling of chemicals and gases.
- CHE-T1-15 Observe and avoid the lower and upper flammability limits (LFL and UFL) of chemicals.
- CHE-T1-16 Understand how to clean chemical spills and contamination.
- CHE-T1-17 Observe the threshold limit value (TLV) of chemical substances.
- CHE-T1-18 Follow and apply proper procedures to protect against fire in the plant.
- CHE-T1-19 Apply proper procedures and precautions to shut down equipment (purging, physical and electrical isolation, checks before line breaking).
- CHE-T1-20 Comprehend the design safety checklist.
- CHE-T1-21 Apply proper procedures and precautions to start up equipment (removal of isolation, removal of interlock bypasses, leak testing).
- CHE-T1-22 Understand and apply the Failure Mode and Effects Analysis (FMEA).
- CHE-T1-23 Perform and apply LCA (Life Cycle Analysis).
- CHE-T1-24 Be familiar with sustainability and sustainable development concepts and tools.
- CHE-T1-25 Be familiar with allowable noise level.
- CHE-T1-26 Understand and follow the emergency plan.
- CHE-T1-27 Develop and follow incidents response procedures.

CHE-T2: Design (11MCQs)

CHE-T2-A Unit Design. (7 MCQs)

- CHE-T2-A-1 Identify and use the factors/parameters/constraints/short cut methods in the design of plants 'units.
- CHE-T2-A-2 Select the reactor type and configuration, e.g. Batch Reactor, Semi batch Reactor, Continuous Stirred Tank Reactor, Plug Flow Reactor, Packed (Fixed) Bed Reactor, and Fluidized Bed Reactor etc.
- CHE-T2-A-3 Identify the factors and their effects on the performance of chemical reactors.



- CHE-T2-A-4 Configure the reactor feeding and heating modes to enhance the selectivity/yield of desired product.
- CHE-T2-A-5 Configure the reactor stirring (stirrer type, baffles) by taking into consideration the reaction and substance parameters (e.g. viscosity).
- CHE-T2-A-6 Recognize and analyze the role of catalysts in chemical reactions.
- CHE-T2-A-7 Apply methods and means that control reactor temperature through heating or cooling using different heat transfer configurations.
- CHE-T2-A-8 Determine feed conditions & position and their implications on the design of separation units.
- CHE-T2-A-9 Specify the minimum and optimum reflux ratio in distillation columns that give the desired product specifications.
- CHE-T2-A-10 Ensure proper tray spacing for optimum operation of a distillation column.
- CHE-T2-A-11 Choose column specifications e.g., height, diameter, and efficiency for optimum operation.
- CHE-T2-A-12 Estimate the diameter of bubble cap trays and the dimensions of the weirs and downcomers and their effects on column performance.
- CHE-T2-A-13 Identify various problems in column (weeping, priming, flooding, foaming).
- CHE-T2-A-14 Determine the Number of Transfer Unit (NTU) and Height of Transfer Unit (HTU) and Volume of Transfer Unit (VTU) in packed bed columns.
- CHE-T2-A-15 Determine optimum packing material size and type in packed bed columns.
- CHE-T2-A-16 Identify the factors that affect the design of absorption units.
- CHE-T2-A-17 Estimate tray efficiency, column diameter and height and their effects on the performance of absorbers and strippers.
- CHE-T2-A-18 Design heat exchangers: shell and tube, and double pipe, and plate heat exchangers.
- CHE-T2-A-19 Design heat exchangers by using rules of thumb.
- CHE-T2-A-20 Choose the proper TEMA (Tubular Exchanger Manufacturing Association) class of heat exchangers.
- CHE-T2-A-21 Recognize the effect of tube pattern (square, triangular...etc) on heat exchanger performance.
- CHE-T2-A-22 Analyze the effect of flow pattern (co-current or counter-current) on the performance of heat exchangers.
- CHE-T2-A-23 Recognize the effect of baffles on pressure drop in heat exchangers.
- CHE-T2-A-24 Estimate the maximum velocity in the shell side of a heat exchanger.
- CHE-T2-A-25 Assess the factors that affect the design and operation of filtration units.



- CHE-T2-A-26 Recognize the main factors that affect the selection of the best evaporator type.
- CHE-T2-A-27 Select the proper pump type (piston, screw, centrifugal...etc), power, properties of liquid, capacity, material of construction, flow rate, required head, pressure...etc.
- CHE-T2-A-28 Identify the operating conditions that affect the design of compressors.
- CHE-T2-A-29 Recognize possibilities to improve the energy balance of a plant by using hot and cold process streams in heat exchangers.
- CHE-T2-A-30 Recognize the main factors that affect the performance of boilers.
- CHE-T2-A-31 Select the type of pipes and their fittings (valves, elbows, tees.... etc.) and their material to minimize the pressure and energy losses.
- CHE-T2-A-32 Select the proper materials of construction of the main and auxiliary units of the plant (corrosion, properties, cost.....etc.).
- CHE-T2-A-33 Consider space and installation requirements for maintenance in the plant design (e.g. space to remove heat exchanger bundle and beam hoist to do so).
- CHE-T2-A-34 Consider the overall impact of breakdown of a single equipment.

CHE-T2-B Process and Plant Design. (4 MCQs)

- CHE-T2-B-1 Pre-design the components of a chemical plant using rules of thumb.
- CHE-T2-B-2 Identify the main factors that need to be considered when designing a plant for a new product.
- CHE-T2-B-3 Identify the main factors that influence the operation of mass transfer processes (distillation, absorption/stripping, liquid-liquid extraction, solid-liquid extraction, humidification, drying, crystallization).
- CHE-T2-B-4 Identify the main factors that influence physical separations (sedimentation, centrifugation, cycloning, filtration, membrane processes).
- CHE-T2-B-5 Identify the physical or chemical properties that determine the selection of the process units in the design (e.g., vapor pressure favors distillation or evaporation).
- CHE-T2-B-6 Observe safety when designing systems of pressurized vessels and boilers.
- CHE-T2-B-7 Assess the factors that determine the optimum selection of plant location.
- CHE-T2-B-8 Assess the factors that determine the optimum selection of plant layout and the position of the various plant components (upwind or downwind) such as offices, boiler, air supply, powerhouse.....etc.
- CHE-T2-B-9 Draw and understand piping & instrument diagrams (P&ID).
- CHE-T2-B-10 Devise and interpret process flow and control diagrams.



- CHE-T2-B-11 Devise and interpret utility flow diagrams.
- CHE-T2-B-12 Devise and interpret process control diagrams.
- CHE-T2-B-13 Include sustainability in the design.
- CHE-T2-B-14 Recognize the major causes of startup delays during the design phase.
- CHE-T2-B-15 Identify the provision of standby equipment for critical areas.
- CHE-T2-B-16 Identify the most critical, critical and non-critical areas of operation.
- CHE-T2-B-17 Provide backup or alternate source of supplies like electric, utilities.
- CHE-T2-B-18 Carry out heat and mass balances and integration for the plant.

CHE-T3: Operation (7 MCQs)

- CHE-T3 -1 Apply procedures and standards to ensure plant operation at design set points.
- CHE-T3 -2 Operate equipment and units at optimum conditions.
- CHE-T3 -3 Apply plant procedures for storing raw materials and products.
- CHE-T3 -4 Ensure adequate supply and quality of raw materials.
- CHE-T3 -5 Maintain the quality of the product.
- CHE-T3 -6 Ensure adequate supply of needed utilities.
- CHE-T3 -7 Apply proper procedures and sequencing in the startup and shutdown of the plant.
- CHE-T3 -8 Apply procedures for typical fault scenarios, e.g. power outage, utility supply failure.
- CHE-T3 -9 Apply analysis to identify bad actors (equipment and instrumentation).
- CHE-T3 -10 Apply logical procedures to trouble shoot and/or debottleneck problems.
- CHE-T3 -11 Apply systems to ensure safe operation of the plant: work permit system, management of change and bypassing of interlocks.
- CHE-T3 -12 Apply procedures to ensure timely preventive maintenance.
- CHE-T3 -13 Identify the factors that affect the performance of compressors.
- CHE-T3 -14 Apply procedures that improve the performance of cooling towers.
- CHE-T3 -15 Avoid problems with cooling towers.
- CHE-T3 -16 Seek ways to improve plant performance.
- CHE-T3 -17 Communicate any deviation in plant performance to the concerned party or upper management.
- CHE-T3 -18 Prepare periodic or upon request professional reports to upper management on the performance of the plant.



**CHE-T4: Management and Economics of CHE Plants****(4 MCQs)**

- CHE-T4 -1 Perform cost estimation of chemical plants (capital and operating costs, depreciation).
- CHE-T4 -2 Conduct profitability analysis and evaluate profitability criteria (e.g., rate of return, payback period, net present value).
- CHE-T4 -3 Develop cash-flow diagrams.
- CHE-T4 -4 Include land, construction costs and VAT in the economics.
- CHE-T4 -5 Perform profitability and sensitivity analysis.
- CHE-T4 -6 Prepare concise economic sheet for upper management.
- CHE-T4 -7 Understand and follow official procedures and requirements to approve and finance a new plant.
- CHE-T4 -8 Understand the responsibility of a project manager in a newly approved chemical plant.
- CHE-T4 -9 Understand the responsibility of a plant manager.
- CHE-T4 -10 Understand the scope, available budget, and schedule of a new project or plant.
- CHE-T4 -11 Define the quality and quantity of the targeted products and raw materials.
- CHE-T4 -12 Assemble the right team of expertise to meet the scope of the project.
- CHE-T4 -13 Perform a conceptual or preliminary design and pre-economics to determine the viability of the project.
- CHE-T4 -14 Perform detailed design that include equipment, utilities, materials, safety and environmental consideration, manpower.... etc.
- CHE-T4 -15 Ensure timely procurement of equipment.
- CHE-T4 -16 Ensure that equipment have their complete accessories and internals before installation and startup.
- CHE-T4 -17 Ensure sufficient expediting (including visits and quality checks) at manufacturer for critical equipment.
- CHE-T4 -18 Ensure timely procurement of raw materials before startup.
- CHE-T4 -19 Ensure adequate storage facilities for raw materials and products.
- CHE-T4 -20 Avoid extra charges due to changes during construction phase of the plant.
- CHE-T4 -21 Get involved in writing an operating manual for startup and shutdown of the plant ahead of plant operation.
- CHE-T4 -22 Set up a system to hand over the finalized project to the operations/start up team and define the scope for hand over.



- CHE-T4 -23 Define the minimum required work force for the running of plant based on shift model.
- CHE-T4 -24 Provide guidelines to achieve targets.
- CHE-T4 -25 Prepare the worker welfare plans.
- CHE-T4 -26 Fulfill the regulatory and statutory requirements to avoid fines or operation stoppage by agencies.
- CHE-T4 -27 Provide the refreshing training to operation and maintenance staff.
- CHE-T4 -28 Provide the operation manuals and technical data.
- CHE-T4 -29 Provide comfortable working environment.
- CHE-T4 -30 Provide the job description and work instructions to all staff.

5. Samples of Questions

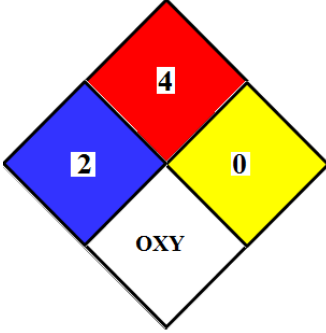
Q. No.	Major Area	Indicator Code	Question Statement (Answer's Choices)	Key Answer	Expected Time (min)	Supplied Reference
1	Health, Safety, and Environment in CHE Plants	CHE-T1-13	<p>Given the following safety and data sheet (SDS) for an organic liquid chemical compound.</p>  <p>The compound is</p> <p>A) highly ignitable, requires medical attention, normally stable, and oxidizing.</p> <p>B) moderately ignitable, requires high medical attention, medium stability, and oxidizing.</p> <p>C) oxidizing, non-ignitable, normally stable, and requires medical attention.</p> <p>D) unstable, highly ignitable, requires medical attention, and oxidizing.</p>	(A)	2.0 - 3.0	None
2	Health, Safety, and Environment in CHE Plants	CHE-T1-15	<p>Consider a mixture of two flammable gases consisting of 70 mol% methane (LFL=4.4 mol%) and the rest ethane (LFL=2.4 mol%). The lower flammability limit (mol%) of the mixture is:</p> <p>A) 6.1</p> <p>B) 5.4</p> <p>C) 4.3</p> <p>D) 3.5</p>	(D)	2.0 - 4.0	None

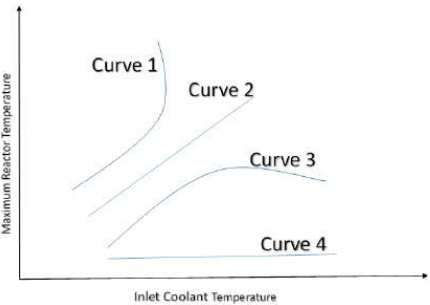
Q. No.	Major Area	Indicator Code	Question Statement (Answer's Choices)	Key Answer	Expected Time (min)	Supplied Reference
3	Health, Safety, and Environment in CHE Plants	CHE-T1-22	<p>The Failure-Mode Effect Analysis (FMEA) determines the effect of a component or equipment failure on the whole plant. It is a procedure that involves many experts in chemistry, design, control, operation ...etc. The risk priority number (RPN) is calculated by multiplying the severity (SEV) by the occurrence (OCC) by detection (DET). The higher RPN, the most attention is needed for that particular component or item. While FMEA helps in many aspects, it does NOT help in the analysis of:</p> <p>A) plant safety B) marketing strategy C) potential causes of failure D) product design</p>	(B)	2.0 - 4.0	None
4	Unit Design	CHE-T2-A-7	<p>A fixed bed reactor in the form of a shell-and-tube heat exchanger, packed with a heterogeneous catalyst is in operation for an exothermic chemical reaction. The reactor is operated nonisothermally. The plot below shows the variations of the maximum reactor temperature with the inlet coolant temperature for four modes of operations indicated by curve 1,2,3, and 4. Based on the temperature profiles shown in the figure, in which manner should the reactor be operated in order to limit a thermal runaway?</p>  <p>A) Curve 1 B) Curve 2 C) Curve 3 D) Curve 4</p>	(B)	3.0 – 4.0	None

Q. No.	Major Area	Indicator Code	Question Statement (Answer's Choices)	Key Answer	Expected Time (min)	Supplied Reference
5	Unit Design	CHE-T2-A-31	<p>In a petrochemical unit operation, liquid benzene at 25°C (density 876 kg/m³ and viscosity 0.6 mPa.s) is to be transferred at a rate of 380 Lpm through a pipe segment which has a length of 60 m. What is the minimum pipe diameter (cm) that can be installed that will result in a pressure drop through the pipe segment not exceeding 0.2 bar? Assume a friction loss of 0.02.</p> <p>A) 7.2 B) 9.2 C) 10.3 D) 12.5</p>	(B)	3 – 4	See Reference
6	Process and Plant Design	CHE-T2-B-7	<p>The construction costs of a bromine plant are less in Buraydah (Al-Qassim Region) while the land and utility costs are less in Al-Muzahimiyah (near Riyadh). Jubail city is located near the east coast of Saudi Arabia and the bromine will be mostly sold in Riyadh. An investor wants to produce bromine from sea water; he approached you as a competent chemical engineer to select a suitable site for his plant. Which city would you choose for the plant given that the concentration of bromine in sea water is about 70 ppm?</p> <p>A) Jubail B) Al-Muzahimiyah C) Buraydah D) Riyadh</p>	(A)	2 – 4	None
7	Process and Plant Design	CHE-T2-B-9	<p>The piping and instrumentation diagram should not contain:</p> <p>A) quality level B) manual switches C) pipe's size D) flow direction</p>	(B)	1– 3	None

Q. No.	Major Area	Indicator Code	Question Statement (Answer's Choices)	Key Answer	Expected Time (min)	Supplied Reference
8	Operation	CHE-T3-2	<p>You are operating a liquid phase, isothermal plug flow reactor where the conversion of the reactant (A) in the reaction ($A \rightarrow P$) is 0.9. The mass flow rate of the feed reactant (m) is 10.35 kg/min and the space time is 10 min. In separate experiments, the conversion (x) of the reactant has been correlated to the ratio (y) of mass flow rate (m) in kg/min to the reactor volume (V) in m^3 by the following equation: $x = 2 \ln(y) + 0.12$. At what volumetric flow rate (m^3/min) would you operate the reactor?</p> <p>A) 0.3 B) 0.5 C) 0.7 D) 0.9</p>	(C)	3.0 – 4.0	None
9	Operation	CHE-T3-9	<p>Which of the following is associated with weeping in a distillation column?</p> <p>A) It increases separation efficiency. B) It provides large interfacial surface for mass transfer. C) It can be detected by a sharp increase in column differential pressure. D) It is caused by low vapor flow.</p>	(D)	1 – 3.0	None
10	Management and Economics of CHE Plants	CHE-T4-2	<p>A company is specialized in producing impellers for a pump. The company wants to buy a new machine for producing these impellers. The cost of the machine is \$400,000. The machine is expected to have a maintenance cost of \$15,000 and a \$30,000 salvage value after its 10-year economic life. If the variable cost for producing each impeller is \$10.5 per unit and the impeller can be sold for \$40.00 per unit, how many impellers per year must the company sell in order to breakeven at an interest rate of 15% per year?</p> <p>A) 2190 B) 2870 C) 3160 D) 3540</p>	(C)	3.0 – 4.0	See Reference

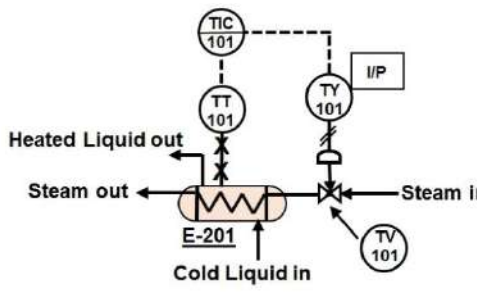

Q. No.	Major Area	Indicator Code	Question Statement (Answer's Choices)	Key Answer	Expected Time (min)	Supplied Reference
Essay (1)	Process and Plant Design	CHE-T2-B-9	<p>A Process and Instrumentation Diagram (P&ID) of a part of chemical plant where a cold liquid is heated by steam is represented by the figure below.</p>  <p>Write an essay that describes each item (lines and components) in this part of the process by interpreting the P&ID.</p>	----	30 - 40	None
Essay (2)	Unit Design	CHE-T2-A-18	<p>In a clean test, water flowing at a fixed rate of 660 L/min is heated from 25°C to 75°C by saturated steam at 120°C. After a few months, the exit temperature of the water was 65°C due to fouling. The water flows in the inner pipe of the heat exchanger. The inner surface area of the pipe is 6 m². Estimate the fouling factor (m². K/kW).</p>		30 - 40	See reference

References

1) Pressure drop in a pipe.

$$\Delta P_f = 4 \rho f \frac{L V^2}{D}$$

D: diameter of pipe

f: friction coefficient

L: length of pipe

V: velocity of fluid

ρ : density

ΔP_f : pressure drop

2) Axisymmetric plumes.

15%		Compound Interest Factors							15%	
n	Single Payment		Uniform Payment Series				Arithmetic Gradient		n	
	Compound Amount Factor Find F Given P	Present Worth Factor Find P Given F	Sinking Fund Factor Find A Given F	Capital Recovery Factor Find A Given P	Compound Amount Factor Find F Given A	Present Worth Factor Find P Given A	Gradient Uniform Series Find A Given G	Gradient Present Worth Find P Given G		
	F/P	P/F	A/F	A/P	F/A	P/A	A/G	P/G		
1	1.150	.8696	1.0000	1.1500	1.000	0.870	0	0	1	
2	1.322	.7561	.4651	.6151	2.150	1.626	0.465	0.756	2	
3	1.521	.6575	.2880	.4380	3.472	2.283	0.907	2.071	3	
4	1.749	.5718	.2003	.3503	4.993	2.855	1.326	3.786	4	
5	2.011	.4972	.1483	.2983	6.742	3.352	1.723	5.775	5	
6	2.313	.4323	.1142	.2642	8.754	3.784	2.097	7.937	6	
7	2.660	.3759	.0904	.2404	11.067	4.160	2.450	10.192	7	
8	3.059	.3269	.0729	.2229	13.727	4.487	2.781	12.481	8	
9	3.518	.2843	.0596	.2096	16.786	4.772	3.092	14.755	9	
10	4.046	.2472	.0493	.1993	20.304	5.019	3.383	16.979	10	
11	4.652	.2149	.0411	.1911	24.349	5.234	3.655	19.129	11	
12	5.350	.1869	.0345	.1845	29.002	5.421	3.908	21.185	12	
13	6.153	.1625	.0291	.1791	34.352	5.583	4.144	23.135	13	
14	7.076	.1413	.0247	.1747	40.505	5.724	4.362	24.972	14	
15	8.137	.1229	.0210	.1710	47.580	5.847	4.565	26.693	15	
16	9.358	.1069	.0179	.1679	55.717	5.954	4.752	28.296	16	
17	10.761	.0929	.0154	.1654	65.075	6.047	4.925	29.783	17	
18	12.375	.0808	.0132	.1632	75.836	6.128	5.084	31.156	18	
19	14.232	.0703	.0113	.1613	88.212	6.198	5.231	32.421	19	
20	16.367	.0611	.00976	.1598	102.444	6.259	5.365	33.582	20	
21	18.822	.0531	.00842	.1584	118.810	6.312	5.488	34.645	21	
22	21.645	.0462	.00727	.1573	137.632	6.359	5.601	35.615	22	
23	24.891	.0402	.00628	.1563	159.276	6.399	5.704	36.499	23	
24	28.625	.0349	.00543	.1554	184.168	6.434	5.798	37.302	24	
25	32.919	.0304	.00470	.1547	212.793	6.464	5.883	38.031	25	
26	37.857	.0264	.00407	.1541	245.712	6.491	5.961	38.692	26	
27	43.535	.0230	.00353	.1535	283.569	6.514	6.032	39.289	27	
28	50.066	.0200	.00306	.1531	327.104	6.534	6.096	39.828	28	
29	57.575	.0174	.00265	.1527	377.170	6.551	6.154	40.315	29	
30	66.212	.0151	.00230	.1523	434.745	6.566	6.207	40.753	30	
31	76.144	.0131	.00200	.1520	500.957	6.579	6.254	41.147	31	
32	87.565	.0114	.00173	.1517	577.100	6.591	6.297	41.501	32	
33	100.700	.00993	.00150	.1515	664.666	6.600	6.336	41.818	33	
34	115.805	.00864	.00131	.1513	765.365	6.609	6.371	42.103	34	
35	133.176	.00751	.00113	.1511	881.170	6.617	6.402	42.359	35	
40	267.864	.00373	.00056	.1506	1779.1	6.642	6.517	43.283	40	
45	538.769	.00186	.00028	.1503	3585.1	6.654	6.583	43.805	45	
50	1083.7	.00092	.00014	.1501	7217.7	6.661	6.620	44.096	50	
55	2179.6	.00046	.00007	.1501	14524.1	6.664	6.641	44.256	55	
60	4384.0	.00023	.00003	.1500	29220.0	6.665	6.653	44.343	60	
65	8817.8	.00011	.00002	.1500	58778.6	6.666	6.659	44.390	65	
70	17735.7	.00006	.00001	.1500	118231.5	6.666	6.663	44.416	70	
75	35672.9	.00003		.1500	237812.5	6.666	6.665	44.429	75	
80	71750.9	.00001		.1500	478332.6	6.667	6.666	44.436	80	
85	144316.7	.00001		.1500	962104.4	6.667	6.666	44.440	85	

3) Heat exchanger equations and data for water.

$$Q = U \times A \times LMTD$$

$$LMTD = \frac{\Delta T_A - \Delta T_B}{\ln\left(\frac{\Delta T_A}{\Delta T_B}\right)}$$

T (°C)	ρ (kg.m ⁻³)	C _p (kJ kg ⁻¹ K ⁻¹)
40	992.3	4.1796
45	990.2	4.1806
50	988.0	4.1815
55	985.6	4.1833

6. Solutions of Sample Questions

Multiple Choice Questions (MCQs)

Question # 1

Indicator CHE-T1-13: Understand and strictly follow Safety Data Sheet (SDS) for raw materials, products and any chemical used in the plant.

Example CHE-T1-13:

Given the following safety and data sheet (SDS) for an organic liquid chemical compound.

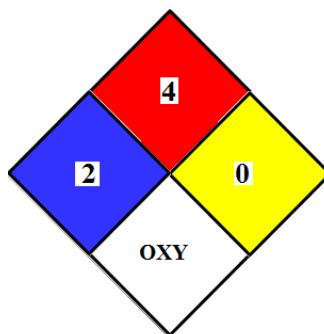

The compound is:

- A) highly ignitable, requires medical attention, normally stable, and oxidizing.
- B) moderately ignitable, requires high medical attention, medium stability, and oxidizing.
- C) oxidizing, non-ignitable, normally stable, and requires medical attention.
- D) unstable, highly ignitable, requires medical attention, and oxidizing.

Solution CHE-T1-13:

From the SDS and according to NFPA (National Fire Protection Association), the severity of the hazards ranges from 0 to 4 (4 being the most severe).

Blue is for health; Red is for ignitability; Yellow is for stability; White is for other comments

Based on the above, prolonged exposure requires medical attention (2), it is highly ignitable under ambient conditions (3), normally stable (0), and it is an oxidant (OXY)

Answer CHE-T1-13: (A)

Question # 2

Indicator CHE-T1-15: Observe and avoid the lower and upper flammability limits (LFL and UFL) of chemicals.

Example CHE-T1-15:

Consider a mixture of two flammable gases consisting of 70 mol% methane (LFL=4.4 mol%) and the rest ethane (LFL=2.4 mol%). The lower flammability limit (mol%) of the mixture is:

- A) 6.1
- B) 5.4
- C) 4.3
- D) 3.5

Solution CHE-T1-15

$$LFL_{mix} = \frac{100}{\frac{70}{4.4} + \frac{30}{2.4}} = 3.5$$

Answer CHE-T1-15: (D)

Question # 3

Indicator CHE-T1-22:

Understand and apply the Failure Mode and Effects Analysis (FMEA).

Example CHE-T1-22:

The Failure-Mode Effect Analysis (FMEA) determines the effect of a component or equipment failure on the whole plant. It is a procedure that involves many experts in chemistry, design, control, operation ...etc. The risk priority number (RPN) is calculated by multiplying the severity (SEV) by the occurrence (OCC) by detection (DET). The higher RPN, the most attention is needed for that particular component or item. While FMEA helps in many aspects, it does **NOT** help in the analysis of:

- A) plant safety
- B) marketing strategy
- C) potential causes of failure
- D) product design

Solution CHE-T1-22

FMEA as stated is not concerned with the development of strategies to market a certain product, but rather focuses on how to maintain the quality of the product by avoiding or minimizing potential failure of plant units or components and to operate under safe conditions.

Answer CHE-T1-22: (B)

Question # 4

Indicator CHE-T2-A-7: Apply methods and means that control reactor temperature through heating or cooling using different heat transfer configurations.

Example CHE-T2-A-7

A fixed bed reactor in the form of a shell-and-tube heat exchanger, packed with a heterogeneous catalyst is in operation for an exothermic chemical reaction. The reactor is operated nonisothermally.

The plot below shows the variations of the maximum reactor temperature with the inlet coolant temperature for four modes of operations indicated by curve 1, 2, 3, and 4.

Based on the temperature profiles shown in the figure, in which manner should the reactor be operated in order to limit a thermal runaway?

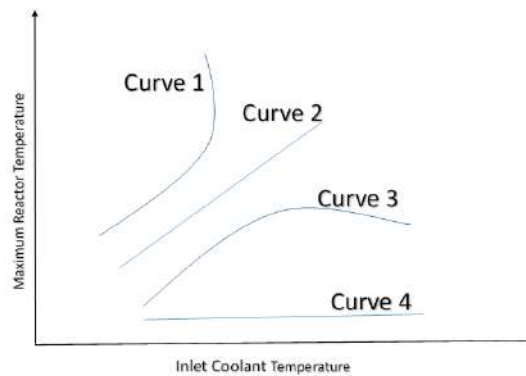

- A) Curve 1
- B) Curve 2
- C) Curve 3
- D) Curve 4

Solution CHE-T2-A-7

To be able to provide a good control of thermal runaway, the system should have a greater ability to remove heat where the heat generated is the highest. The slope of each curve provides an indication of the reactor stability to variations in the inlet coolant temperature. Curve 2 provides the best option.

Answer CHE-T2-A-7: (B)

Question # 5

Indicator CHE-T2-A-31: Select the type of pipes and their fittings (valves, elbows, tees.... etc.) and their material to minimize the pressure and energy losses.

Example CHE-T2-A-31:

In a petrochemical unit operation, liquid benzene at 25°C (density 876 kg/m³ and viscosity 0.6 mPa.s) is to be transferred at a rate of 380 Lpm through a pipe segment which has a length of 60 m. What is the minimum pipe diameter (cm) that can be installed that will result in a pressure drop through the pipe segment not exceeding 0.2 bar? Assume a friction loss of 0.02 .

- A) 7.2
- B) 9.2
- C) 10.3
- D) 12.5

$$V=Q/A=4Q/\pi D^2$$

Using the equation given in reference and substituting yields

$$\Delta P_f = 4 \rho f \frac{L V^2}{D} = 2 \rho f \frac{L 16 Q^2}{D \pi^2 D^4} = \frac{32 L Q^2 \rho f}{\pi^2 D^5}$$

This yields

$$D^5 = \frac{32 L Q^2 \rho f}{\pi^2 \Delta P_f}$$

Substituting yields

$$D=0.092 \text{ m} =9.2 \text{ cm}$$

Answer CHE-T2-A-31: (B)



Question # 6

Indicator CHE-T2-B-7:

Assess the factors that determine the optimum selection of plant location.

Example CHE-T2-B-7

The construction cost of a bromine plant is less in Buraydah (Al-Qassim Region) while the land and utility costs are less in Al-Muzahimiyah (near Riyadh). Jubail city is located near the east coast of Saudi Arabia and the bromine will be mostly sold in Riyadh. An investor wants to produce bromine from sea water; he approached you as a competent chemical engineer to select a suitable site for his plant. Which city would you choose for the plant? given that the concentration of bromine in sea water is about 70 ppm.

- A) Jubail
- B) Al-Muzahimiyah
- C) Buraydah
- D) Riyadh

Solution CHE-T2-B-7:

Despite the fact that Buraydah enjoys least construction cost, Al-Muzahimiyah enjoys less land and utility cost, and Riyadh is the main market for bromine, the proper choice is Jubail because of its closeness to the sea where the raw material is found. At a level of 70 ppm of bromine, the transportation cost of sea water to any location will off-set any gains in market, land and utility, and construction costs.

Answer CHE-T2-B-7: (A)



Question # 7

Indicator CHE-T2-B-9: Draw and understand piping & instrument diagrams (P&ID).

Example CHE-T2-B-9

The piping and instrumentation diagram should **not** contain:

- A) quality level.
- B) manual switches.
- C) pipe's size.
- D) flow direction.

Solution CHE-T2-B-9

Manual switches are not included in the P&ID.

Answer CHE-T2-B-9: (B)

Question # 8

Indicator CHE-T3-2: Operate equipment and units at optimum conditions.

Example CHE-T3-2:

You are operating a liquid phase, isothermal plug flow reactor where the conversion of the reactant (A) in the reaction ($A \rightarrow P$) is 0.9. The mass flow rate of the feed reactant (m) is 10.35 kg/min and the space time is 10 min. In separate experiments, the conversion (x) of the reactant has been correlated to the ratio (y) of mass flow rate (m) in kg/min to the reactor volume (V) in m^3 by the following equation: $x = 2 \ln(y) + 0.12$. At what volumetric flow rate (m^3/min) would you operate the reactor?

- A) 0.3
- B) 0.5
- C) 0.7
- D) 0.9

Solution CHE-T3-2

From the equation

$$y = \exp\left(\frac{0.9 - 0.12}{2}\right) = 1.477$$

$$V = \frac{m}{y} = \frac{10.35}{1.477} = 7$$

$$\text{volumetric flow rate} = v = \frac{V}{\tau} = \frac{7}{10} = 0.7$$

Answer CHE-T3-2: (C)



Question # 9

Indicator CHE-T3-9:

Apply analysis to identify bad actors (equipment and instrumentation).

Example CHE-T3-9

Which is of the following is associated with weeping in a distillation column?

- A) It increases separation efficiency.
- B) It provides large interfacial surface for mass transfer.
- C) It can be detected by a sharp increase in column differential pressure.
- D) It is caused by low vapor flow.

Solution CHE-T3-9

Weeping is caused by low vapor flow and leads to decreased separation efficiency.

Answer CHE-T3-9: (D)



Question # 10

Indicator CHE-T4-2:

Conduct profitability analysis and evaluate profitability criteria (e.g., rate of return, payback period, net present value).

Example CHE-T4-2

A company is specialized in producing impellers for a pump. The company wants to buy a new machine for producing these impellers. The cost of the machine is \$400,000. The machine is expected to have a maintenance cost of \$15,000 and an \$30,000 salvage value after its 10-year economic life. If the variable cost for producing each impeller is \$10.5 per unit and the impeller can be sold for \$40.00 per unit, how many impellers per year must the company sell in order to breakeven at an interest rate of 15% per year?

- A) 2190
- B) 2870
- C) 3160
- D) 3540

Solution CHE-T4-2:

Let n the number of impellers to be produced per year in order to break even.

Writing the annual worth equation:

$$0 = -400,000 (A/P, 15\%, 10) - 15,000 + 30,000 (A/F, 15\%, 10) - 10.5n + 40n$$

Using the sheet given in the reference we have:

$$0 = -400,000 (0.1993) - 15,000 + 30,000 (0.0493) + 29.5n$$

$$29.5n = 93241$$

$$n = 3160 \text{ impellers per year}$$

Answer CHE-T4-2: (C)



Essay Question

Essay Question # 1

Indicator CHE-T2-B-9 Draw and understand piping & instrument diagrams (P&ID).

A Process and Instrumentation Diagram (P&ID) of a part of chemical plant where a cold liquid is heated by steam is represented by the figure below.

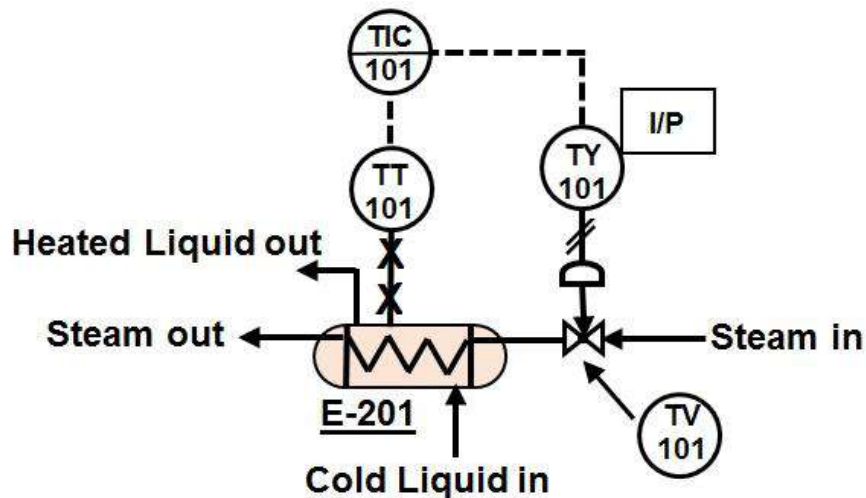

Write an essay that describes each item (lines and components) in this part of the process by interpreting the P&ID.

Answer to Essay Question # 1

The cold liquid passes into the heat exchanger (E-201) where it is heated to the required temperature by steam. The tag number "101" indicates the control system in the P&ID. The signal from the heat exchanger is sensed by a capillary tube denoted by a solid line with "X". The temperature transmitter (TT-101) transmits an electronic signal to the temperature indicator and recorder (TIC-101). Electronic signals in the P&ID are indicated by dashed lines. Circles without a cross line indicate a field mounted device whereas those with a cross line indicate board mounted devices (i.e., shown in the control room). The TIC transmits an electronic signal to the temperature transducer (TY-101) where the electronic signal is converted into a pressure signal indicated by the square that encloses the letters I/P. The temperature transducer (TY) controls the steam flow. The pneumatic connection is indicated by the diagonally crossed line. The half circle on the top of the pneumatic valve (TV-101) indicates the actuator that controls the flow of steam into the heat exchanger by changing the position of the pneumatic valve (TV-101).

Indicator CHE-T2-A-18: Design heat exchangers: shell and tube, and double pipe, and plate heat exchangers.

In a clean test, water flowing at a fixed rate of 660 L/min is heated from 25°C to 75°C by saturated steam at 120°C. After a few months, the exit temperature of the water was 65°C due to fouling. The water flows in the inner pipe of the heat exchanger. The inner surface area of the pipe is 6 m². Estimate the fouling factor (m². K/kW).

Answer to Essay Question # 2

For the clean tube:

$$\text{The bulk temperature of water} = \frac{(25+75)}{2} = 50^{\circ}\text{C}$$

$$\text{From the Table given in reference: } \rho = 988 \frac{\text{kg}}{\text{m}^3} \text{ and } C_p = 4.1815 \frac{\text{kJ}}{\text{kg.K}}$$

$$m_w = 988 \times \frac{660}{1000} \times \frac{1}{60} = 10.87 \frac{\text{kg}}{\text{s}}$$

$$\text{Heat load when clean} = Q_{\text{clean}} = 10.87 \times 4.1815 \times (75 - 25) = 2272.6 \text{ kW}$$

$$\begin{aligned} \text{Log Mean Temperature Difference} = LMTDF &= \frac{(120 - 25) - (120 - 75)}{\ln\left(\frac{120 - 25}{120 - 75}\right)} = 66.92^{\circ}\text{C} \\ &= 66.92\text{K} \end{aligned}$$

$$\text{Inner tube area} = A_{\text{in}} = 6 \text{ m}^2$$

$$U \text{ for clean tube} = U_{\text{clean}} = \frac{Q_{\text{clean}}}{A_{\text{in}} \times LMTD} = \frac{2272.6}{6 \times 66.92} = 5.66 \frac{\text{kW}}{\text{m}^2 \text{ K}}$$

For the fouled tube:

$$\text{The bulk temperature of water} = \frac{(25+65)}{2} = 45^{\circ}\text{C}$$

$$\text{From the Table given in reference: } \rho = 990.2 \frac{\text{kg}}{\text{m}^3} \text{ and } C_p = 4.1806 \frac{\text{kJ}}{\text{kg.K}}$$

$$m_w = 990.2 \times \frac{660}{1000} \times \frac{1}{60} = 10.89 \frac{\text{kg}}{\text{s}}$$

$$\text{Heat load when fouled} = Q_{\text{fouled}} = 10.89 \times 4.1806 \times (65 - 25) = 1821.1 \text{ kW}$$

$$\begin{aligned} \text{Log Mean Temperature Difference} = LMTDF &= \frac{(120 - 25) - (120 - 65)}{\ln\left(\frac{120 - 25}{120 - 65}\right)} = 73.19^{\circ}\text{C} \\ &= 73.19\text{K} \end{aligned}$$

$$\text{Inner tube area} = A_{\text{in}} = 6 \text{ m}^2$$

$$U \text{ for fouled tube} = U_{\text{fouled}} = \frac{Q_{\text{fouled}}}{A_{\text{in}} \times LMTD} = \frac{1821.1}{6 \times 73.19} = 4.15 \frac{\text{kW}}{\text{m}^2 \text{ K}}$$

$$\text{Fouling factor} = \frac{1}{U_{\text{fouled}}} - \frac{1}{U_{\text{clean}}} = \frac{1}{4.15} - \frac{1}{5.66} = 0.064 \frac{\text{m}^2 \cdot \text{K}}{\text{kW}}$$





هيئة تقويم التعليم والتدريب

Education & Training Evaluation Commission



www.etec.gov.sa

