

Engineering Fundamentals Exam

Study Guide For Mechanical Engineering Exam



COPYRIGHT NOTICE

Copyrights © 2014 National Center for Assessment in Higher Education (QIYAS) and Saudi Council of Engineers (SCE) Unless stated otherwise, copyright in this report (including content and design) is owned by the National Center for Assessment in Higher Education (QIYAS) - Riyadh – Saudi Arabia. EXCEPT with the expressed written permission from QIYAS, you may not reproduce, use (in particular for academic or commercial purposes), store in a retrieval system, adapt, modify, communicate to the public or photocopy any part of this report.

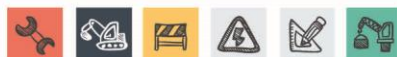

1. Objectives

The aim of this manual is to provide guidelines for the examinees about the exam structure, timing, percentage of question coverage and distribution among various topic areas. In essence, the manual represents the bridge between the developed Mechanical Engineering Standards and the actual phrased questions, which constitute the tests to be administered. It is designed to familiarize the examinees with the test questions formats and contents.

2. Contents

This study guide contains essential information for the examinees. Specifically, the following topics are presented in this manual:

- Exam structure, exam schedule and organization, exam type, eligibility for exam, and exam rules
- Organization of the exam framework
- Table of Specifications which includes an overview of the table, its structure and contents
- Sample of questions and solutions for the Mechanical Engineering discipline



3. Exam Structure

The exam is conducted in two sessions and the duration of each session is 3 hours.

3.1 General Engineering Exam

The first session covers the General Engineering topics. These include the following fourteen topics:

1. Mathematics
2. Probability and Statistics
3. Computer Literacy
4. Statics and Dynamics
5. Chemistry
6. Thermodynamics
7. Fluid Mechanics
8. Materials Science and Engineering
9. Electricity and Magnetism
10. Engineering Drawing
11. Engineering Economics
12. Project Management
13. Ethics
14. General Skills
 - a. Use analytical thinking (logical deductions, statements and assumptions, cause and effect, verbal reasoning, analyzing arguments, statements and conclusions, break a complex problem into smaller problems and solve them)
 - b. Use effective communication in writing, orally, and graphically
 - c. Work cooperatively with other team members to deliver the required outcomes
 - d. Set goals and ways for personal development
 - e. Strive for ways to resolve conflicts while being sensitive to others opinions
 - f. Be able to use time and available resources in an efficient way
 - g. Recognize and interpret environmental, social, cultural, political and safety considerations in engineering solutions.
 - h. Recognize decision making process
 - i. Recognize major engineering concepts outside the discipline.
 - j. Interpret uncertainties in measurements and calculations
 - k. Analyze and interpret data



1. Apply evaluation criteria and contemporary knowledge to select the optimum design from alternative solutions

3.2 Engineering Discipline Exam

The second session covers the Engineering Standards and is based on topics associated with one of the following engineering disciplines:

<i>Code</i>	<i>Discipline</i>
CE	Civil Engineering
CHE	Chemical Engineering
EE	Electrical Engineering
IE	Industrial Engineering
ME	Mechanical Engineering
SE	Structural Engineering

4. Exam Implementation

The exam consists of two sessions:

- The first session consists of General Engineering Exam. The total duration of this session is 3 hours with a total number of 90 questions.
- The second session consists of Engineering Discipline Exam. This session consists of 50 questions with a total time of 3 hours.

5. Exam Type

The exam is initially paper-based and will become computer based in a later stage. The exam, in both sessions, is of a multiple choice type where each question has four choices for the answer. There is no negative marking for wrong answers.



6. Eligibility for the Exam

Bachelor degree holders in an Engineering discipline i.e., Chemical Engineering, Civil Engineering, Electrical Engineering, Industrial Engineering, Mechanical Engineering, and Structural Engineering.

7. Exam Rules

- Books, lecture notes, or any type of materials are not allowed in the exam. Necessary reference sheets, monographs, equations, relevant data from codes will be provided in the exam.
- Calculators approved by Exam authorities are allowed.
- Admission in the examination center will be only through authorized admission card
- Examinees are subjected to all the rules and procedures applied by National Center for Assessment in Higher Education (Qiyas)

8. Organization of the Exam Framework

The core topics constitute the basis of this Engineering Exam. Indicators are used to describe the knowledge to be tested in each topic. Each of these indicators is further subdivided into three major levels following the recent Bloom's taxonomy of learning levels (Remembering and Understanding; Applying and Analyzing; and Evaluating and Creating).

Example

Topic Area:	T1: Mechanical Design and Analysis
Indicator:	ME-T1-06: Evaluate design alternatives based on quality and reliability principles
Learning Level:	Applying and Analyzing (AA)



9. Table of Specifications

9.1 Overview

The Table of Specifications is a map which facilitates the transformation of the Engineering Standards for each Topic Area into balanced and coherent question sheets to be used in the proposed Exam. The Table of Specifications is essentially a tableau structure which distributes, vertically, the exam Questions among various Topic Areas in accordance with the applicable Engineering Standards and, horizontally, over various Learning Levels (Remembering and Understanding, Applying and Analyzing, Evaluating and Creating).

9.2 Structure and Contents

The table below constitutes the Table of Specifications for the Mechanical Engineering Discipline. The Table of Specifications contains the following columns:

9.2.1 Topic Area

These are the widely recognized Topic areas, which are covered in the Mechanical Engineering Discipline, namely:

1. Mechanical Design and Analysis
2. Engineering Mechanics
3. System Dynamics and Control
4. Material Processing and Manufacturing
5. Measurements and Instrumentation
6. Thermodynamics and Thermal Systems
7. Fluid Mechanics and Fluid Machinery
8. Heat Transfer

9.2.2 % of Test

This column summarizes the total percentage (of the total test) allocated for each Topic Area.



9.2.3 Suggested Number of Questions

This column indicates the number of questions to be allocated for each Engineering Standard. The total number of questions per test conforms to the general guidelines which govern the total duration of the test. In the present case, 50 questions are included in each Discipline.

9.2.4 Engineering Standards

This column lists the Engineering Standards to be addressed under each Topic Area.

Standards are coded **ME-TJ** (where **ME** denotes the Mechanical Engineering Discipline, **TJ** denotes the Topic Number **J**), whereas the Indicators are coded **ME-TJ-K** (where **K** denotes the Indicator number).

For example: **ME-T1-6** is for the question in Mechanical Engineering (ME) that represents Topic 1 (Mechanical Design and Analysis) and Indicator 6.

9.2.5 Assigned Allocations among Learning Levels

The three sub-columns (Remembering and Understanding, Applying and Analyzing, and Evaluating and Creating) under this main column specify the question distribution for the Topic among the three Learning Levels. For example, for the Mechanical Design and Analysis (ME-T1), there are two questions assigned to Learning Level **RU**, five questions for **AA** and one question for **EC**.

It is to be noted that the Learning Levels used in the Table of Specifications represent the so-called cognitive levels/processes (levels of thinking) in the revised Bloom's taxonomy. Every two consecutive Learning Levels in Bloom's are combined as one level here.

It is also important to note that the distribution of questions among various Topic Areas follows a careful and rigorous question allocation process, which ensures that appropriate relative levels of coverage are maintained for the various Learning Levels. In the Mechanical Engineering Discipline, the distribution of questions (for all Topics) among the three *Learning Levels* is 16 questions (32%) for Remembering and Understanding, 26 questions (52%) for Applying and Analyzing, and 8 questions (16%) for Evaluating and Creating.



Table of Specifications for Mechanical Engineering Exam

Topic Area	% of Test	# Q	Engineering Standard	Assigned Allocations among Learning Levels		
				RU	AA	EC
1- Mechanical Design and Analysis	16%	8	ME-T1	2	5	1
2- Engineering Mechanics	14%	7	ME-T2	2	4	1
3- System Dynamics and Control	10%	5	ME-T3	2	2	1
4- Material Processing and Manufacturing	10%	5	ME-T4	3	1	1
5- Measurements and Instrumentation	8%	4	ME-T5	1	2	1
6- Thermodynamics and Thermal Systems	16%	8	ME-T6	3	4	1
7- Fluid Mechanics and Fluid Machinery	16%	8	ME-T7	2	5	1
8- Heat Transfer	10%	5	ME-T8	1	3	1
Total	100%	50		32% (16 Q's)	52% (26 Q's)	16% (8 Q's)

RU: Remembering & Understanding **AA:** Applying & Analyzing **EC:** Evaluating & Creating



10. Sample Questions

A sample of questions is shown in the following tabular format in accordance with the following instructions.

1. For Learning Levels
 - RU for Remembering and Understanding
 - AA for Applying and Analyzing
 - EC for Evaluating and Creating
2. References sheets are denoted in the last column of the Table

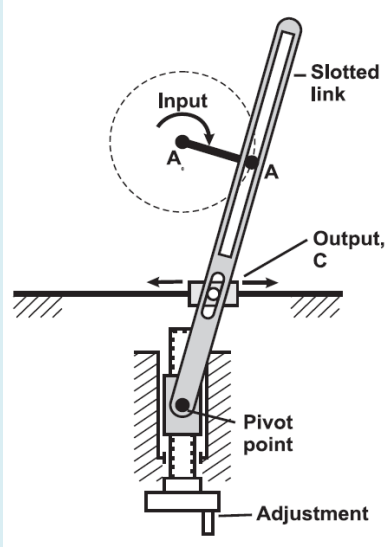

Table of Sample Questions

Q. No.	Topic Area	EA Code	Learning Level	Question Statement (Answer's Choices)	Key Answer	Expected Time (min)	Supplied Reference
1	Mechanical Design and Analysis	ME-T1-02	RU	<p>The property of a material which enables it to resist fracture due to high impact loads is known as:</p> <p>a) endurance b) strength c) toughness d) resilience</p>	c	2 - 2.5	None
2	Engineering Mechanics	ME-T2-01	RU	<p>In the shown slider-driven quick-return mechanism, moving the pivot point downward:</p>  <p>a) increases the output time-ratio b) decreases the output time-ratio c) increases the output cycle-time d) decreases the output cycle-time</p>	b	2.0 - 2.5	None

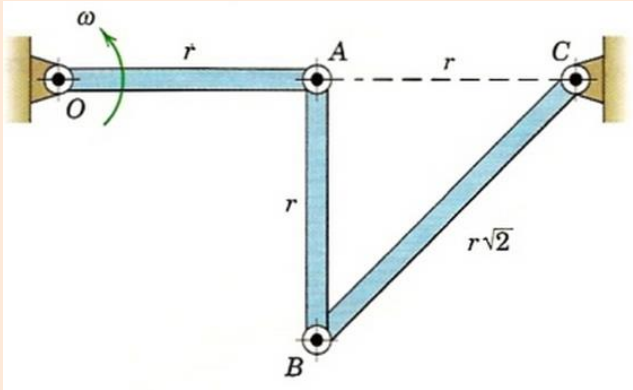

3	Engineering Mechanics	ME-T2-05	AA	<p>Link OA has a constant counter clockwise angular velocity $\omega = 4$ rad/s during a short interval of its motion. Considering $r = 0.3$ m, for the position shown in the figure the angular velocity ω_{BC} (rad/s) of link BC is: (negative sign indicates CW direction)</p>  <p>a) - 0.75 b) - 1.33 c) - 4.00 d) - 4.50</p>	c	4.0 – 5.0	Reference #3
4	Material Processing and Manufacturing	ME-T4-02	RU	<p>The maximum solubility of carbon in ferrite and austenite, respectively is:</p> <p>a) 0.022 and 2.14 wt% b) 3.0 and 4.2 wt% c) 0.76 and 6.7 wt% d) 2.14 and 6.7 wt%</p>	a	2.0 – 2.5	Reference #4



5	Measurements and Instrumentation	ME-T5-01	AA	<p>The mean coil diameter D_m of a spring, given by the manufacturer, is 41 mm. The measured values of the diameter by a Vernier caliper are 42, 41, 40, 41, 42, 40 mm. Using 95% confidence level, the estimated total uncertainty (mm) of the measurement is about:</p> <p>a) 0.90 b) 0.92 c) 0.94 d) 0.96</p>	c	3.0 – 4.0	Reference #5
6	Thermodynamics and Thermal Systems	ME-T6-04	AA	<p>50 kg/s of steam are expanded isentropically from 2.5 MPa and 600°C to a pressure of 10 kPa. The power output of the turbine (MW) is:</p> <p>a) 56 b) 60 c) 64 d) 68</p>	c	4.0 – 5.0	Reference #6



7	Fluid Mechanics and Fluid Machinery	ME-T7-10	AA	<p>The pump and system characteristics of a water pump at a speed of 1450 rpm are as follows:</p> $H_{\text{pump}} = 70 - 5Q^2$ $H_{\text{system}} = 7.5Q^2$ <p>Where H is the head developed (m) and Q is the volume flow rate (m³/min). The head (m) developed at the operating point of the pump is:</p> <p>a) 36 b) 42 c) 48 d) 54</p>	b	3.0 – 4.0	None
8	Heat Transfer	ME-T8-01	AA	<p>A window glass pane is 1m x 2m in size and has a thickness of 10 mm. The temperatures on the inner side and the outer side of the glass pane are 15⁰ C and 45⁰ C, respectively. If the coefficient of thermal conductivity of the glass is 0.78 W/m⁻⁰ C then the rate of heat transfer (Watts) through the glass is:</p> <p>a) 4380 b) 4480 c) 4580 d) 4680</p>	d	3.0 – 4.0	None



Reference # 3

$$\vec{v}_B = \vec{v}_A + \vec{v}_{B/A}$$

$$\vec{v}_{B/A} = \vec{\omega}_{AB} \times \vec{r}_{B/A}$$

Reference # 4

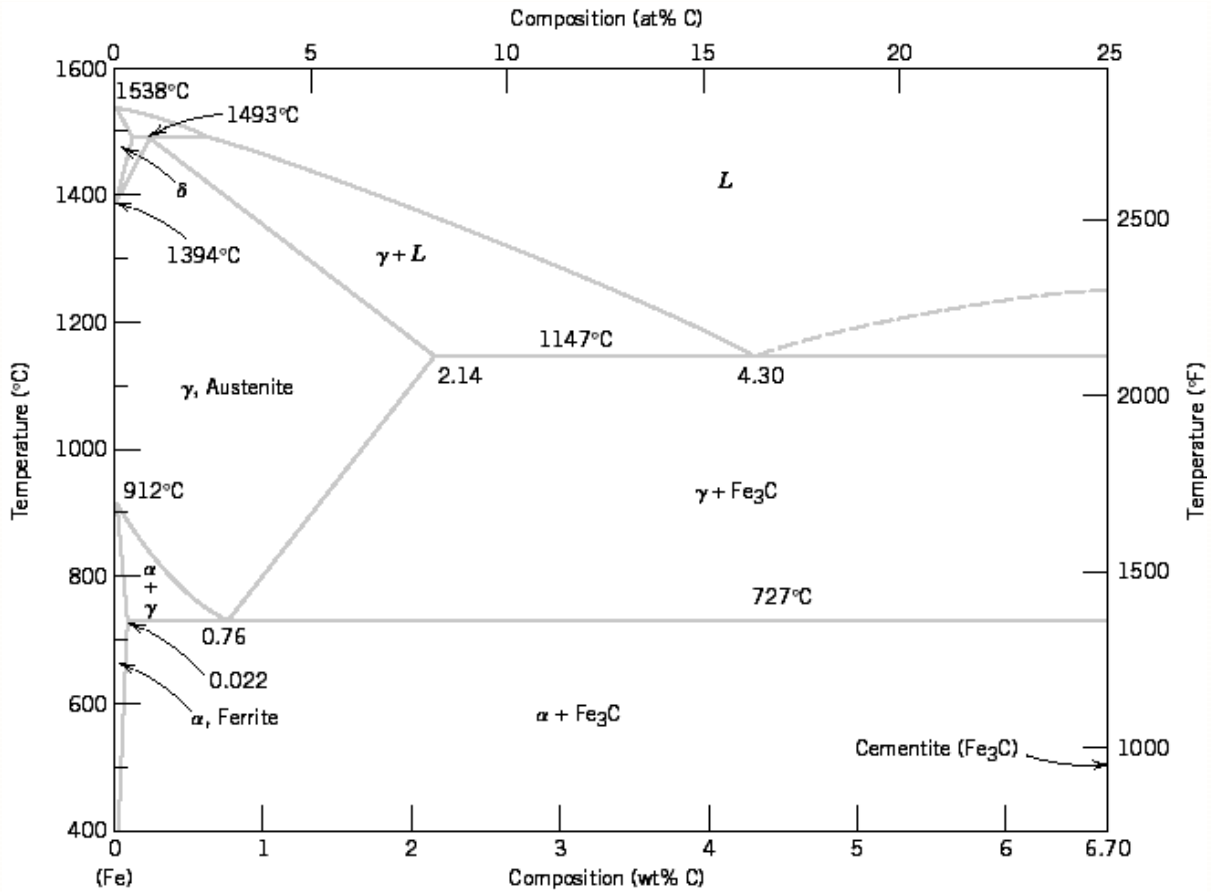

Reference # 5

$$\bar{D}_M = \frac{\sum_{i=1}^n D_i}{n} = 41 \text{ mm}$$

$$S_D = \sqrt{\frac{\sum_{i=1}^n (D_i - \bar{D}_M)^2}{n - 1}} = 0.894 \text{ mm}$$

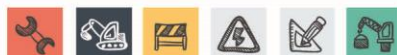

Student's t-distribution (values of $t_{\alpha/2, \nu}$)

ν	$t_{0.10}$	$t_{0.05}$	$t_{0.025}$	$t_{0.01}$	$t_{0.005}$	ν
1	3.078	6.314	12.706	31.821	63.657	1
2	1.886	2.92	4.303	6.965	9.925	2
3	1.638	2.353	3.182	4.541	5.841	3
4	1.533	2.132	2.776	3.747	4.604	4
5	1.476	2.015	2.571	3.365	4.032	5
6	1.44	1.943	2.447	3.143	3.707	6
7	1.415	1.895	2.365	2.998	3.499	7
8	1.397	1.86	2.306	2.896	3.355	8
9	1.383	1.833	2.262	2.821	3.25	9
10	1.372	1.812	2.228	2.764	3.169	10



Reference # 6

Saturated water—Pressure table

Press., <i>P</i> kPa	Sat. temp., <i>T</i> _{sat} °C	Specific volume, m ³ /kg		Internal energy, kJ/kg			Enthalpy, kJ/kg			Entropy, kJ/kg · K		
		Sat. liquid, <i>v</i> _f	Sat. vapor, <i>v</i> _g	Sat. liquid, <i>u</i> _f	Evap., <i>u</i> _{fg}	Sat. vapor, <i>u</i> _g	Sat. liquid, <i>h</i> _f	Evap., <i>h</i> _{fg}	Sat. vapor, <i>h</i> _g	Sat. liquid, <i>s</i> _f	Evap., <i>s</i> _{fg}	Sat. vapor, <i>s</i> _g
1.0	6.97	0.001000	129.19	29.302	2355.2	2384.5	29.303	2484.4	2513.7	0.1059	8.8690	8.9749
1.5	13.02	0.001001	87.964	54.686	2338.1	2392.8	54.688	2470.1	2524.7	0.1956	8.6314	8.8270
2.0	17.50	0.001001	66.990	73.431	2325.5	2398.9	73.433	2459.5	2532.9	0.2606	8.4621	8.7227
2.5	21.08	0.001002	54.242	88.422	2315.4	2403.8	88.424	2451.0	2539.4	0.3118	8.3302	8.6421
3.0	24.08	0.001003	45.654	100.98	2306.9	2407.9	100.98	2443.9	2544.8	0.3543	8.2222	8.5765
4.0	28.96	0.001004	34.791	121.39	2293.1	2414.5	121.39	2432.3	2553.7	0.4224	8.0510	8.4734
5.0	32.87	0.001005	28.185	137.75	2282.1	2419.8	137.75	2423.0	2560.7	0.4762	7.9176	8.3938
7.5	40.29	0.001008	19.233	168.74	2261.1	2429.8	168.75	2405.3	2574.0	0.5763	7.6738	8.2501
10	45.81	0.001010	14.670	191.79	2245.4	2437.2	191.81	2392.1	2583.9	0.6492	7.4996	8.1488
15	53.97	0.001014	10.020	225.93	2222.1	2448.0	225.94	2372.3	2598.3	0.7549	7.2522	8.0071
20	60.06	0.001017	7.6481	251.40	2204.6	2456.0	251.42	2357.5	2608.9	0.8320	7.0752	7.9073
25	64.96	0.001020	6.2034	271.93	2190.4	2462.4	271.96	2345.5	2617.5	0.8932	6.9370	7.8302
30	69.09	0.001022	5.2287	289.24	2178.5	2467.7	289.27	2335.3	2624.6	0.9441	6.8234	7.7675
40	75.86	0.001026	3.9933	317.58	2158.8	2476.3	317.62	2318.4	2636.1	1.0261	6.6430	7.6691
50	81.32	0.001030	3.2403	340.49	2142.7	2483.2	340.54	2304.7	2645.2	1.0912	6.5019	7.5931
75	91.76	0.001037	2.2172	384.36	2111.8	2496.1	384.44	2278.0	2662.4	1.2132	6.2426	7.4558
100	99.61	0.001043	1.6941	417.40	2088.2	2505.6	417.51	2257.5	2675.0	1.3028	6.0562	7.3589
101.325	99.97	0.001043	1.6734	418.95	2087.0	2506.0	419.06	2256.5	2675.6	1.3069	6.0476	7.3545
125	105.97	0.001048	1.3750	444.23	2068.8	2513.0	444.36	2240.6	2684.9	1.3741	5.9100	7.2841
150	111.35	0.001053	1.1594	466.97	2052.3	2519.2	467.13	2226.0	2693.1	1.4337	5.7894	7.2231
175	116.04	0.001057	1.0037	486.82	2037.7	2524.5	487.01	2213.1	2700.2	1.4850	5.6865	7.1716
200	120.21	0.001061	0.88578	504.50	2024.6	2529.1	504.71	2201.6	2706.3	1.5302	5.5968	7.1270
225	123.97	0.001064	0.79329	520.47	2012.7	2533.2	520.71	2191.0	2711.7	1.5706	5.5171	7.0877
250	127.41	0.001067	0.71873	535.08	2001.8	2536.8	535.35	2181.2	2716.5	1.6072	5.4453	7.0525
275	130.58	0.001070	0.65732	548.57	1991.6	2540.1	548.86	2172.0	2720.9	1.6408	5.3800	7.0207
300	133.52	0.001073	0.60582	561.11	1982.1	2543.2	561.43	2163.5	2724.9	1.6717	5.3200	6.9917
325	136.27	0.001076	0.56199	572.84	1973.1	2545.9	573.19	2155.4	2728.6	1.7005	5.2645	6.9650
350	138.86	0.001079	0.52422	583.89	1964.6	2548.5	584.26	2147.7	2732.0	1.7274	5.2128	6.9402
375	141.30	0.001081	0.49133	594.32	1956.6	2550.9	594.73	2140.4	2735.1	1.7526	5.1645	6.9171
400	143.61	0.001084	0.46242	604.22	1948.9	2553.1	604.66	2133.4	2738.1	1.7765	5.1191	6.8955
450	147.90	0.001088	0.41392	622.65	1934.5	2557.1	623.14	2120.3	2743.4	1.8205	5.0356	6.8561
500	151.83	0.001093	0.37483	639.54	1921.2	2560.7	640.09	2108.0	2748.1	1.8604	4.9603	6.8207
550	155.46	0.001097	0.34261	655.16	1908.8	2563.9	655.77	2096.6	2752.4	1.8970	4.8916	6.7886
600	158.83	0.001101	0.31560	669.72	1897.1	2566.8	670.38	2085.8	2756.2	1.9308	4.8285	6.7593
650	161.98	0.001104	0.29260	683.37	1886.1	2569.4	684.08	2075.5	2759.6	1.9623	4.7699	6.7322
700	164.95	0.001108	0.27278	696.23	1875.6	2571.8	697.00	2065.8	2762.8	1.9918	4.7153	6.7071
750	167.75	0.001111	0.25552	708.40	1865.6	2574.0	709.24	2056.4	2765.7	2.0195	4.6642	6.6837



Saturated water—Pressure table (Continued)

Press., <i>P</i> kPa	Sat. temp., T_{sat} °C	Specific volume, m ³ /kg		Internal energy, kJ/kg			Enthalpy, kJ/kg			Entropy, kJ/kg · K		
		Sat. liquid, v_f	Sat. vapor, v_g	Sat. liquid, u_f	Evap., u_{fg}	Sat. vapor, u_g	Sat. liquid, h_f	Evap., h_{fg}	Sat. vapor, h_g	Sat. liquid, s_f	Evap., s_{fg}	Sat. vapor, s_g
800	170.41	0.001115	0.24035	719.97	1856.1	2576.0	720.87	2047.5	2768.3	2.0457	4.6160	6.6616
850	172.94	0.001118	0.22690	731.00	1846.9	2577.9	731.95	2038.8	2770.8	2.0705	4.5705	6.6409
900	175.35	0.001121	0.21489	741.55	1838.1	2579.6	742.56	2030.5	2773.0	2.0941	4.5273	6.6213
950	177.66	0.001124	0.20411	751.67	1829.6	2581.3	752.74	2022.4	2775.2	2.1166	4.4862	6.6027
1000	179.88	0.001127	0.19436	761.39	1821.4	2582.8	762.51	2014.6	2777.1	2.1381	4.4470	6.5850
1100	184.06	0.001133	0.17745	779.78	1805.7	2585.5	781.03	1999.6	2780.7	2.1785	4.3735	6.5520
1200	187.96	0.001138	0.16326	796.96	1790.9	2587.8	798.33	1985.4	2783.8	2.2159	4.3058	6.5217
1300	191.60	0.001144	0.15119	813.10	1776.8	2589.9	814.59	1971.9	2786.5	2.2508	4.2428	6.4936
1400	195.04	0.001149	0.14078	828.35	1763.4	2591.8	829.96	1958.9	2788.9	2.2835	4.1840	6.4675
1500	198.29	0.001154	0.13171	842.82	1750.6	2593.4	844.55	1946.4	2791.0	2.3143	4.1287	6.4430
1750	205.72	0.001166	0.11344	876.12	1720.6	2596.7	878.16	1917.1	2795.2	2.3844	4.0033	6.3877
2000	212.38	0.001177	0.099587	906.12	1693.0	2599.1	908.47	1889.8	2798.3	2.4467	3.8923	6.3390
2250	218.41	0.001187	0.088717	933.54	1667.3	2600.9	936.21	1864.3	2800.5	2.5029	3.7926	6.2954
2500	223.95	0.001197	0.079952	958.87	1643.2	2602.1	961.87	1840.1	2801.9	2.5542	3.7016	6.2558
3000	233.85	0.001217	0.066667	1004.6	1598.5	2603.2	1008.3	1794.9	2803.2	2.6454	3.5402	6.1856
3500	242.56	0.001235	0.057061	1045.4	1557.6	2603.0	1049.7	1753.0	2802.7	2.7253	3.3991	6.1244
4000	250.35	0.001252	0.049779	1082.4	1519.3	2601.7	1087.4	1713.5	2800.8	2.7966	3.2731	6.0696
5000	263.94	0.001286	0.039448	1148.1	1448.9	2597.0	1154.5	1639.7	2794.2	2.9207	3.0530	5.9737
6000	275.59	0.001319	0.032449	1205.8	1384.1	2589.9	1213.8	1570.9	2784.6	3.0275	2.8627	5.8902
7000	285.83	0.001352	0.027378	1258.0	1323.0	2581.0	1267.5	1505.2	2772.6	3.1220	2.6927	5.8148
8000	295.01	0.001384	0.023525	1306.0	1264.5	2570.5	1317.1	1441.6	2758.7	3.2077	2.5373	5.7450
9000	303.35	0.001418	0.020489	1350.9	1207.6	2558.5	1363.7	1379.3	2742.9	3.2866	2.3925	5.6791
10,000	311.00	0.001452	0.018028	1393.3	1151.8	2545.2	1407.8	1317.6	2725.5	3.3603	2.2556	5.6159
11,000	318.08	0.001488	0.015988	1433.9	1096.6	2530.4	1450.2	1256.1	2706.3	3.4299	2.1245	5.5544
12,000	324.68	0.001526	0.014264	1473.0	1041.3	2514.3	1491.3	1194.1	2685.4	3.4964	1.9975	5.4939
13,000	330.85	0.001566	0.012781	1511.0	985.5	2496.6	1531.4	1131.3	2662.7	3.5606	1.8730	5.4336
14,000	336.67	0.001610	0.011487	1548.4	928.7	2477.1	1571.0	1067.0	2637.9	3.6232	1.7497	5.3728
15,000	342.16	0.001657	0.010341	1585.5	870.3	2455.7	1610.3	1000.5	2610.8	3.6848	1.6261	5.3108
16,000	347.36	0.001710	0.009312	1622.6	809.4	2432.0	1649.9	931.1	2581.0	3.7461	1.5005	5.2466
17,000	352.29	0.001770	0.008374	1660.2	745.1	2405.4	1690.3	857.4	2547.7	3.8082	1.3709	5.1791
18,000	356.99	0.001840	0.007504	1699.1	675.9	2375.0	1732.2	777.8	2510.0	3.8720	1.2343	5.1064
19,000	361.47	0.001926	0.006677	1740.3	598.9	2339.2	1776.8	689.2	2466.0	3.9396	1.0860	5.0256
20,000	365.75	0.002038	0.005862	1785.8	509.0	2294.8	1826.6	585.5	2412.1	4.0146	0.9164	4.9310
21,000	369.83	0.002207	0.004994	1841.6	391.9	2233.5	1888.0	450.4	2338.4	4.1071	0.7005	4.8076
22,000	373.71	0.002703	0.003644	1951.7	140.8	2092.4	2011.1	161.5	2172.6	4.2942	0.2496	4.5439
22,064	373.95	0.003106	0.003106	2015.7	0	2015.7	2084.3	0	2084.3	4.4070	0	4.4070



Superheated water (Continued)

<i>T</i> °C	<i>v</i> m ³ /kg	<i>u</i> kJ/kg	<i>h</i> kJ/kg	<i>s</i> kJ/kg · K	<i>v</i> m ³ /kg	<i>u</i> kJ/kg	<i>h</i> kJ/kg	<i>s</i> kJ/kg · K	<i>v</i> m ³ /kg	<i>u</i> kJ/kg	<i>h</i> kJ/kg	<i>s</i> kJ/kg · K
<i>P</i> = 1.00 MPa (179.88°C)				<i>P</i> = 1.20 MPa (187.96°C)				<i>P</i> = 1.40 MPa (195.04°C)				
Sat.	0.19437	2582.8	2777.1	6.5850	0.16326	2587.8	2783.8	6.5217	0.14078	2591.8	2788.9	6.4675
200	0.20602	2622.3	2828.3	6.6956	0.16934	2612.9	2816.1	6.5909	0.14303	2602.7	2803.0	6.4975
250	0.23275	2710.4	2943.1	6.9265	0.19241	2704.7	2935.6	6.8313	0.16356	2698.9	2927.9	6.7488
300	0.25799	2793.7	3051.6	7.1246	0.21386	2789.7	3046.3	7.0335	0.18233	2785.7	3040.9	6.9553
350	0.28250	2875.7	3158.2	7.3029	0.23455	2872.7	3154.2	7.2139	0.20029	2869.7	3150.1	7.1379
400	0.30661	2957.9	3264.5	7.4670	0.25482	2955.5	3261.3	7.3793	0.21782	2953.1	3258.1	7.3046
500	0.35411	3125.0	3479.1	7.7642	0.29464	3123.4	3477.0	7.6779	0.25216	3121.8	3474.8	7.6047
600	0.40111	3297.5	3698.6	8.0311	0.33395	3296.3	3697.0	7.9456	0.28597	3295.1	3695.5	7.8730
700	0.44783	3476.3	3924.1	8.2755	0.37297	3475.3	3922.9	8.1904	0.31951	3474.4	3921.7	8.1183
800	0.49438	3661.7	4156.1	8.5024	0.41184	3661.0	4155.2	8.4176	0.35288	3660.3	4154.3	8.3458
900	0.54083	3853.9	4394.8	8.7150	0.45059	3853.3	4394.0	8.6303	0.38614	3852.7	4393.3	8.5587
1000	0.58721	4052.7	4640.0	8.9155	0.48928	4052.2	4639.4	8.8310	0.41933	4051.7	4638.8	8.7595
1100	0.63354	4257.9	4891.4	9.1057	0.52792	4257.5	4891.0	9.0212	0.45247	4257.0	4890.5	8.9497
1200	0.67983	4469.0	5148.9	9.2866	0.56652	4468.7	5148.5	9.2022	0.48558	4468.3	5148.1	9.1308
1300	0.72610	4685.8	5411.9	9.4593	0.60509	4685.5	5411.6	9.3750	0.51866	4685.1	5411.3	9.3036
<i>P</i> = 1.60 MPa (201.37°C)				<i>P</i> = 1.80 MPa (207.11°C)				<i>P</i> = 2.00 MPa (212.38°C)				
Sat.	0.12374	2594.8	2792.8	6.4200	0.11037	2597.3	2795.9	6.3775	0.09959	2599.1	2798.3	6.3390
225	0.13293	2645.1	2857.8	6.5537	0.11678	2637.0	2847.2	6.4825	0.10381	2628.5	2836.1	6.4160
250	0.14190	2692.9	2919.9	6.6753	0.12502	2686.7	2911.7	6.6088	0.11150	2680.3	2903.3	6.5475
300	0.15866	2781.6	3035.4	6.8864	0.14025	2777.4	3029.9	6.8246	0.12551	2773.2	3024.2	6.7684
350	0.17459	2866.6	3146.0	7.0713	0.15460	2863.6	3141.9	7.0120	0.13860	2860.5	3137.7	6.9583
400	0.19007	2950.8	3254.9	7.2394	0.16849	2948.3	3251.6	7.1814	0.15122	2945.9	3248.4	7.1292
500	0.22029	3120.1	3472.6	7.5410	0.19551	3118.5	3470.4	7.4845	0.17568	3116.9	3468.3	7.4337
600	0.24999	3293.9	3693.9	7.8101	0.22200	3292.7	3692.3	7.7543	0.19962	3291.5	3690.7	7.7043
700	0.27941	3473.5	3920.5	8.0558	0.24822	3472.6	3919.4	8.0005	0.22326	3471.7	3918.2	7.9509
800	0.30865	3659.5	4153.4	8.2834	0.27426	3658.8	4152.4	8.2284	0.24674	3658.0	4151.5	8.1791
900	0.33780	3852.1	4392.6	8.4965	0.30020	3851.5	4391.9	8.4417	0.27012	3850.9	4391.1	8.3925
1000	0.36687	4051.2	4638.2	8.6974	0.32606	4050.7	4637.6	8.6427	0.29342	4050.2	4637.1	8.5936
1100	0.39589	4256.6	4890.0	8.8878	0.35188	4256.2	4889.6	8.8331	0.31667	4255.7	4889.1	8.7842
1200	0.42488	4467.9	5147.7	9.0689	0.37766	4467.6	5147.3	9.0143	0.33989	4467.2	5147.0	8.9654
1300	0.45383	4684.8	5410.9	9.2418	0.40341	4684.5	5410.6	9.1872	0.36308	4684.2	5410.3	9.1384
<i>P</i> = 2.50 MPa (223.95°C)				<i>P</i> = 3.00 MPa (233.85°C)				<i>P</i> = 3.50 MPa (242.56°C)				
Sat.	0.07995	2602.1	2801.9	6.2558	0.06667	2603.2	2803.2	6.1856	0.05706	2603.0	2802.7	6.1244
225	0.08026	2604.8	2805.5	6.2629								
250	0.08705	2663.3	2880.9	6.4107	0.07063	2644.7	2856.5	6.2893	0.05876	2624.0	2829.7	6.1764
300	0.09894	2762.2	3009.6	6.6459	0.08118	2750.8	2994.3	6.5412	0.06845	2738.8	2978.4	6.4484
350	0.10979	2852.5	3127.0	6.8424	0.09056	2844.4	3116.1	6.7450	0.07680	2836.0	3104.9	6.6601
400	0.12012	2939.8	3240.1	7.0170	0.09938	2933.6	3231.7	6.9235	0.08456	2927.2	3223.2	6.8428
450	0.13015	3026.2	3351.6	7.1768	0.10789	3021.2	3344.9	7.0856	0.09198	3016.1	3338.1	7.0074
500	0.13999	3112.8	3462.8	7.3254	0.11620	3108.6	3457.2	7.2359	0.09919	3104.5	3451.7	7.1593
600	0.15931	3288.5	3686.8	7.5979	0.13245	3285.5	3682.8	7.5103	0.11325	3282.5	3678.9	7.4357
700	0.17835	3469.3	3915.2	7.8455	0.14841	3467.0	3912.2	7.7590	0.12702	3464.7	3909.3	7.6855
800	0.19722	3656.2	4149.2	8.0744	0.16420	3654.3	4146.9	7.9885	0.14061	3652.5	4144.6	7.9156
900	0.21597	3849.4	4389.3	8.2882	0.17988	3847.9	4387.5	8.2028	0.15410	3846.4	4385.7	8.1304
1000	0.23466	4049.0	4635.6	8.4897	0.19549	4047.7	4634.2	8.4045	0.16751	4046.4	4632.7	8.3324
1100	0.25330	4254.7	4887.9	8.6804	0.21105	4253.6	4886.7	8.5955	0.18087	4252.5	4885.6	8.5236
1200	0.27190	4466.3	5146.0	8.8618	0.22658	4465.3	5145.1	8.7771	0.19420	4464.4	5144.1	8.7053
1300	0.29048	4683.4	5409.5	9.0349	0.24207	4682.6	5408.8	8.9502	0.20750	4681.8	5408.0	8.8786



11. Solution of the Sample Questions

Question # 1

Topic Area: Mechanical Design and Analysis

Learning Level: Remembering & Understanding

Indicator: ME-T1-02 Recognize the fundamental concepts of failure, stability, fatigue and fracture theories

Question Statement:

The property of a material which enables it to resist fracture due to high impact loads is known as:

- a) endurance
- b) strength
- c) toughness
- d) resilience

Answer:

(c)

Estimated Solution Time by Examinee: 2.0 – 2.5 minutes

Remarks: The objective of this question is to ensure that the examinee can identify the principle failure mechanisms and terminology.

Supplied Reference: None

Solution:

Remember definition and terminology

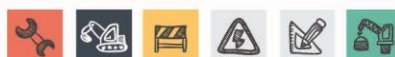

Question # 2

Topic Area: **Engineering Mechanics**

Learning Level: Remembering & Understanding

Indicator: **ME-T2-01** Describe the fundamentals of kinematics of particles and kinematics of rigid bodies in plane motion

Question Statement:

In the shown slider-driven quick-return mechanism, moving the pivot point downward:

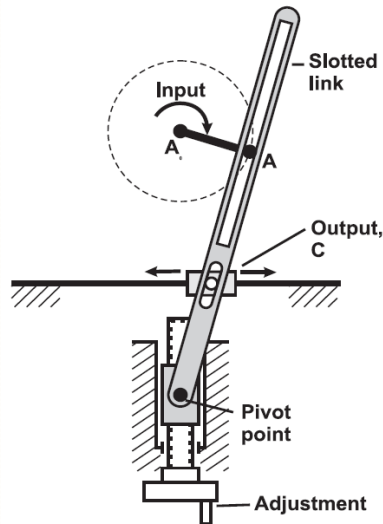

- a) increases the output time-ratio
- b) decreases the output time-ratio
- c) increases the output cycle-time
- d) decreases the output cycle-time

Answer:

(b)

Estimated Solution Time by Examinee: 2.0 – 2.5 minutes

Remarks: The objective of this question is to ensure that the examinee knows the basics of mechanisms geometry, motion and functions

Supplied Reference: None

Solution:

Simple graphical analysis of motion on the provided figure.

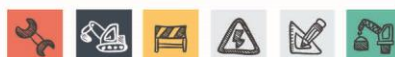

Question # 3

Topic Area: **System Dynamics and Control**

Learning Level: Application and Analysis

Indicator: **ME-T2-05** Develop position, velocity, and acceleration analysis of linkages

Question Statement:

Link OA has a constant counter clockwise angular velocity $\omega = 4$ rad/s during a short interval of its motion. Considering $r = 0.3$ m, for the position shown in the figure the angular velocity ω_{BC} (rad/s) of link BC is:

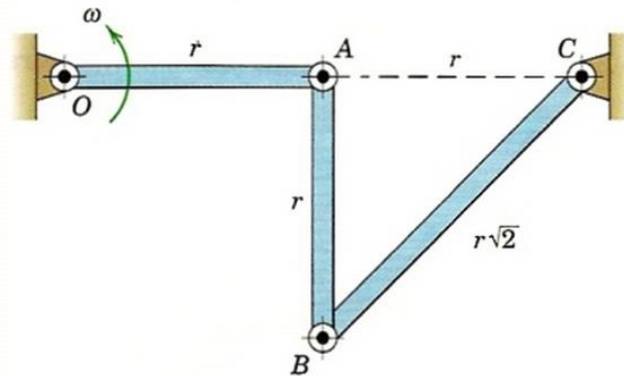

- a) -0.75
- b) -1.33
- c) -4.00
- d) -4.50

Answer:

(c)

Estimated Solution Time by Examinee: 4.0 – 5.0 minutes

Remarks: The objective of this question is to ensure that the examinee knows how to develop position, velocity, and acceleration analysis of linkages.

Supplied Reference: Reference #3

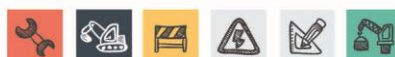

Solution:

$$\vec{V}_A = \vec{V}_O + 4\vec{k} \times 0.3\vec{i} = 1.2\vec{j} \text{ m/s}$$

$$\vec{V}_B = \vec{V}_A + \omega_{AB}\vec{k} \times \vec{r}_{B/A} = 1.2\vec{j} + \omega_{AB}\vec{k} \times -0.3\vec{j}$$

$$\vec{V}_B = 1.2\vec{j} + 0.3\omega_{AB}\vec{i} \quad (1)$$

$$\vec{V}_B = \vec{V}_C + \omega_{BC}\vec{k} \times \vec{r}_{B/C} = \vec{0} + \omega_{BC}\vec{k} \times (-0.3\vec{i} - 0.3\vec{j})$$

$$\vec{V}_B = -0.3\omega_{BC}\vec{j} + 0.3\omega_{BC}\vec{i} \quad (2)$$

From Equations (1) and (2)

$$\vec{i}: 0.3\omega_{AB} = 0.3\omega_{BC} \rightarrow \omega_{AB} = \omega_{BC}$$

$$\vec{j}: 1.2 = -0.3\omega_{BC} \rightarrow \omega_{BC} = -4 \frac{\text{rad}}{\text{s}} = \omega_{AB}$$



Question # 4

Topic Area: Material Processing and Manufacturing

Learning Level: Remembering & Understanding

Indicator: ME-T4-02 Describe equilibrium-phase diagrams

Question Statement:

The maximum solubility of carbon in ferrite and austenite, respectively is:

- a) 0.022 and 2.14 wt%
- b) 3.0 and 4.2 wt%
- c) 0.76 and 6.7 wt%
- d) 2.14 and 6.7 wt%

Answer:

(a)

Estimated solution time by examinee: 2.0- 2.5 minutes

Remarks: The question tests the ability of the student to identify the phases and their composition that are present in phase diagrams to predict the resultant microstructure of the material as a function of temperature and compositions.

Supplied Reference: Reference #4

Solution:

The Ferrite (BCC) has a maximum solubility of 0.022 at 727°C and the Austenite (FCC) has a maximum solubility of 2.14 at 1147°C as shown in the diagram. Hence the correct solution is 0.022 and 2.14 wt% (a).



Question # 5

Topic Area: Measurements and Instrumentation

Learning Level: Application and Analysis

Indicator: ME-T5-01 Identify measurement concepts such as uncertainty analysis and instrumentation specifications.

Question Statement:

The mean coil diameter D_m of a spring, given by the manufacturer, is 41 mm. The measured values of the diameter by a Vernier caliper are 42, 41, 40, 41, 42, 40 mm. Using 95% confidence level, the estimated total uncertainty (mm) of the measurement is about:

- a) 0.90
- b) 0.92
- c) 0.94
- d) 0.96

Answer:

(c)

Estimated Solution Time by Examinee: 3 to 4 minutes

Remarks: The objective of this question is to ensure that the examinee can identify and analyze measurement uncertainties.

Supplied Reference: Reference #5

Solution:

$$\bar{D}_M = \frac{\sum_{i=1}^{i=n} D_i}{n} = 41 \text{ mm}$$

$$S_D = \sqrt{\frac{\sum_{i=1}^{i=n} (D_i - \bar{D}_M)^2}{n - 1}} = 0.894 \text{ mm}$$

$n = 6$ Therefore $\nu = 6 - 1 = 5$; Confidence $C = 0.95$ therefore Significance $\alpha = 0.05$

$$t_{\frac{\alpha}{2}, \nu} = 2.571$$

Therefore

The bias uncertainty U_B is True value - mean value = 0 mm

The precision Uncertainty = $\pm t_{\frac{\alpha}{2}, \nu} \frac{S_D}{\sqrt{n}} = 0.94 \text{ mm}$

The total uncertainty = $\sqrt{U_B^2 + U_p^2} = 0.94$

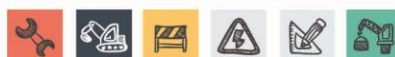

Question # 6

Topic Area: Thermodynamics and Thermal Systems

Learning Level: Application and Analysis

Indicator: ME-T6-04 Use the appropriate laws/ tables for obtaining properties of steam, refrigerant and air.

Question Statement:

50 kg/s of steam are expanded isentropically from 2.5 MPa and 600°C to a pressure of 10 kPa. The power output of the turbine (MW) is:

- a) 56
- b) 60
- c) 64
- d) 68

Answer:

(c)

Estimated solution time by examinee: 4.0-5.0 minutes

Remarks: The question evaluates the ability of the student to recognize and apply the fundamental concepts of thermodynamics to analyze open systems.

Supplied Reference: Reference #6

Solution:

At the entry to the turbine:

At 2.5 MPa, saturation temperature = 223.990 °C therefore steam is super-heated.

From super-heated table specific enthalpy and specific entropy at 2.5 MPa and 600 °C is;

$$h = 3686.3 \text{ kJ/kg}$$

$$s = 7.5960 \text{ kJ/kg-K}$$

At the exit of the turbine:

The pressure = 10 kPa and $s = 7.5960 \text{ kJ/kg-K}$;

From the pressure table s_g = saturation entropy at 10 kPa is 8.1502 kJ/kg-K.

Since $s_g > s$ therefore the condition of the steam at the exit of the turbine is a mixture.

Hence we need to find the quality of the steam:

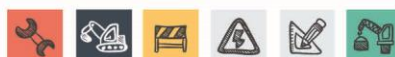

The quality of steam x is calculated from $s = s_f + x * s_{fg}$

That means $7.5960 = 0.6493 + x * 7.5009$ or $x = 0.9254$

Therefore the enthalpy can be calculated from $h = h_f + x * h_{fg}$

$$h = 191.83 + 0.9254 * 2392.8 = 2406.6 \text{ kJ/kg}$$

The power output = mass flow rate * Change in specific enthalpy = $50 * (3686.3 - 2406.6) = 64$ MW

Question # 7

Topic Area: Fluid Mechanics and Fluid Machinery

Learning Level: Application and Analysis

Indicator: ME-T7-10 Evaluate the operating point, power requirement and efficiency of a pumping system using pump-system characteristics

Question Statement:

The pump and system characteristics of a water pump at a speed of 1450 rpm are as follows:

$$H_{\text{pump}} = 70 - 5Q^2$$

$$H_{\text{system}} = 7.5Q^2$$

Where H is the head developed (m) and Q is the volume flow rate (m^3/min). The head (m) developed at the operating point of the pump is:

- a) 36
- b) 42
- c) 48
- d) 54

Answer:

(b)

Estimated solution time by examinee: 3.0 – 4.0 minutes

Remarks: The question tests the ability of the student in recognizing and applying the basic fundamentals of turbomachinery characteristics.

Supplied Reference: None

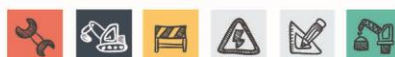

Solution:

The student is able to evaluate the operating point, power requirement and efficiency of a pumping system using pump-system characteristics.

At the operating point, the pump head and the system head are the same. Therefore, equating two equations gives,

$$H_{\text{pump}} = H_{\text{system}} \text{ gives } 70 - 5 Q^2 = 7.5 Q^2 \text{ or } Q^2 = 5.6 \text{ or } Q = 2.366 \text{ m}^3/\text{min}$$

Substituting this value in one of the equations gives H as 42 meters.

Question # 8

Topic Area: Heat Transfer

Learning Level: Application and Analysis

Indicator: ME-T8-01 Recognize the use of laws of heat transfer by conduction.

Question Statement:

A window glass pane is 1m x 2m in size and has a thickness of 10 mm. The temperatures on the inner side and the outer side of the glass pane are 15⁰ C and 45⁰ C, respectively. If the coefficient of thermal conductivity of the glass is 0.78 W/m-⁰ C then the rate of heat transfer (Watts) through the glass is:

- a) 4380
- b) 4480
- c) 4580
- d) 4680

Answer:

(d)

Estimated Solution Time by Examinee: 3.0 to 4.0 minutes

Remarks: The objective of this question is to ensure that the examinee identifies and applies the appropriate heat transfer principle.

Supplied Reference: None



Solution:

The heat transfer through a solid surface having a face temperature difference of $\Delta T^{\circ}\text{C}$, a face area of A (m^2), a thermal conductivity of K ($\text{W}/\text{m}\text{-}^{\circ}\text{C}$) and a thickness of L (m) is given by:

$$Q = KA \frac{\Delta T}{L}$$

Substituting the values $Q = 4680$ Watts



